

Längsschnitt Heute 1:250



Längsschnitt RHESI 1:250




Schnitt A - A Stütze 3 1:50

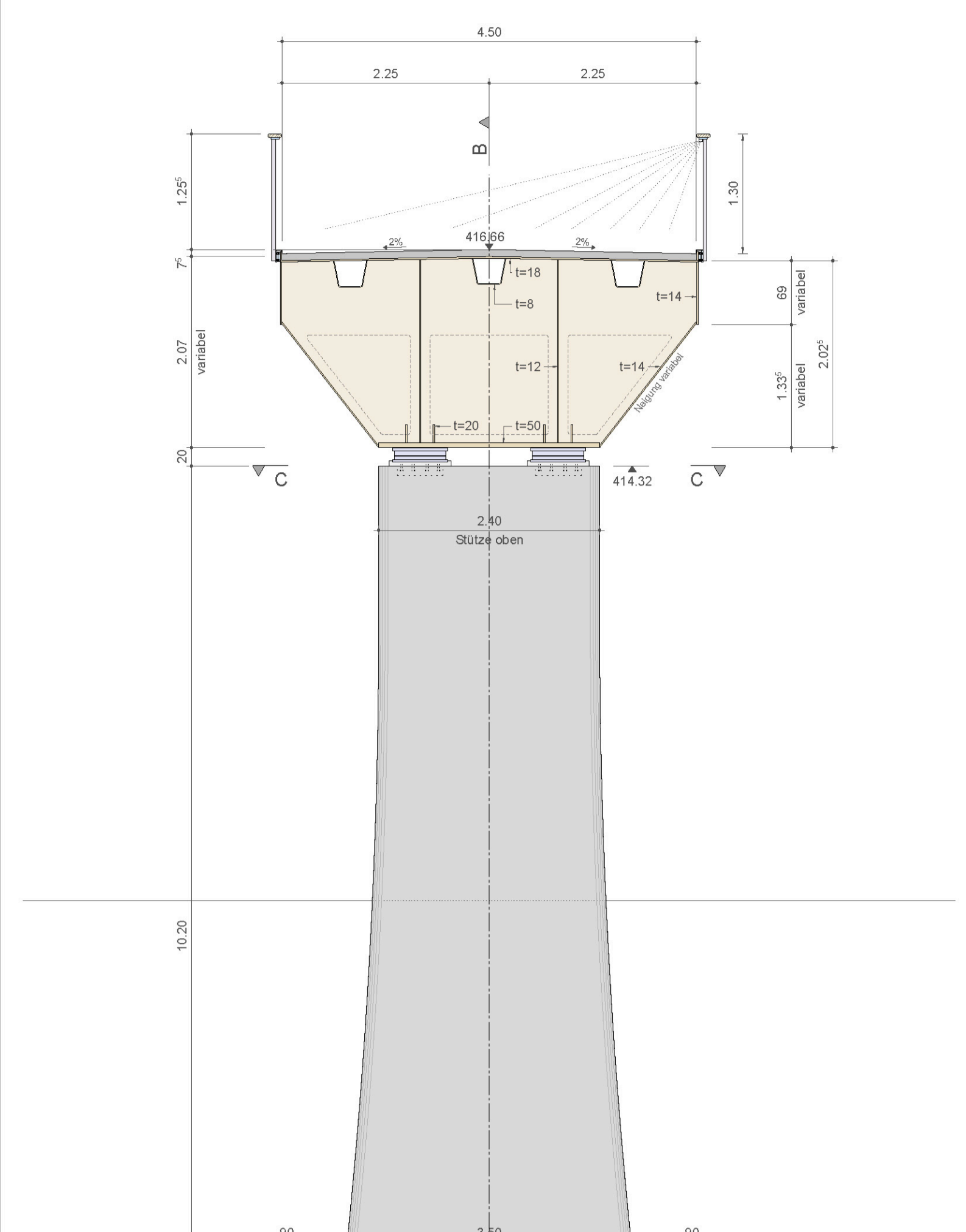

Schnitt B - B Stütze 3 1:50

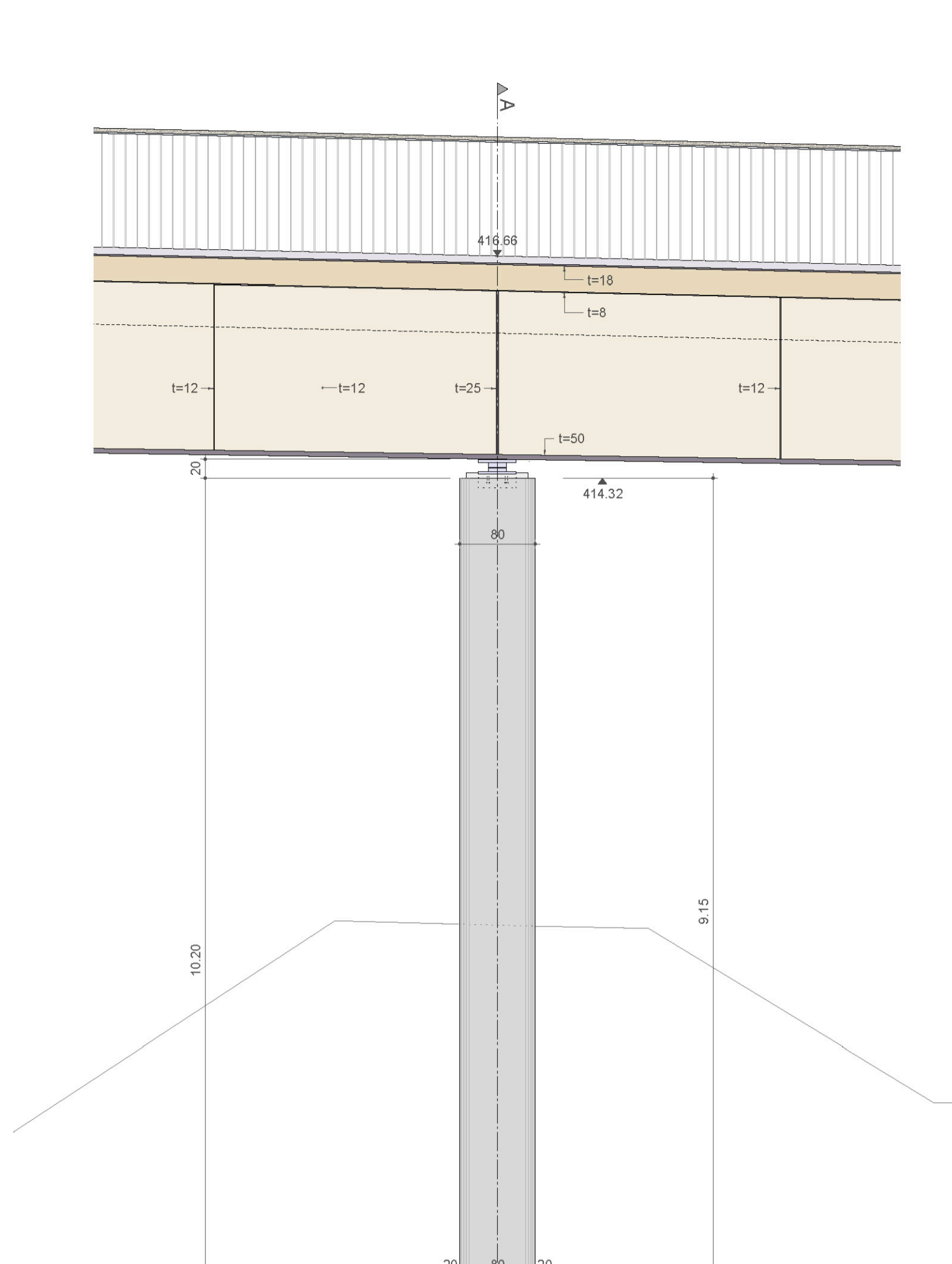

Normalquerschnitt 1:50

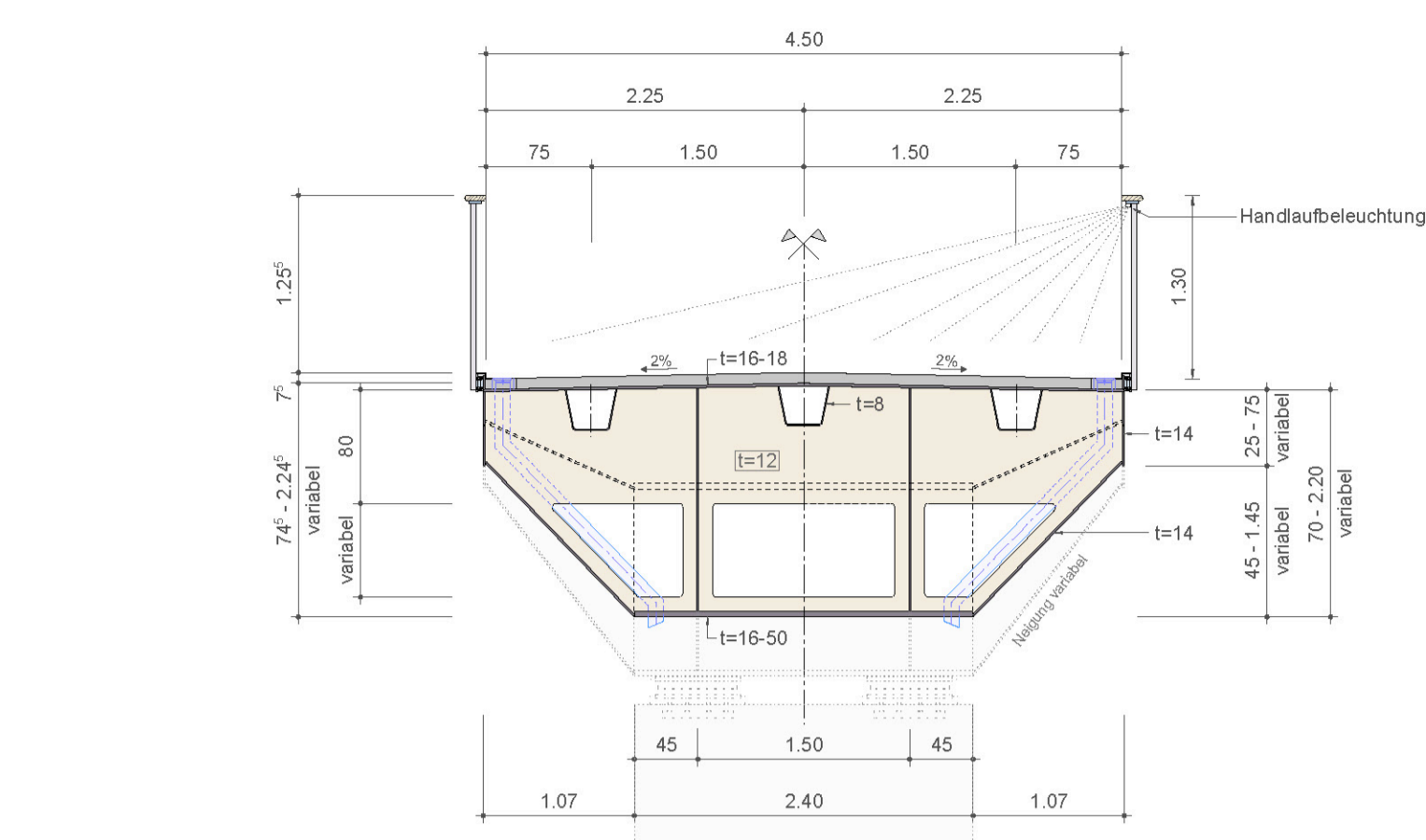

Detail Fahrbahnübergang 1:10

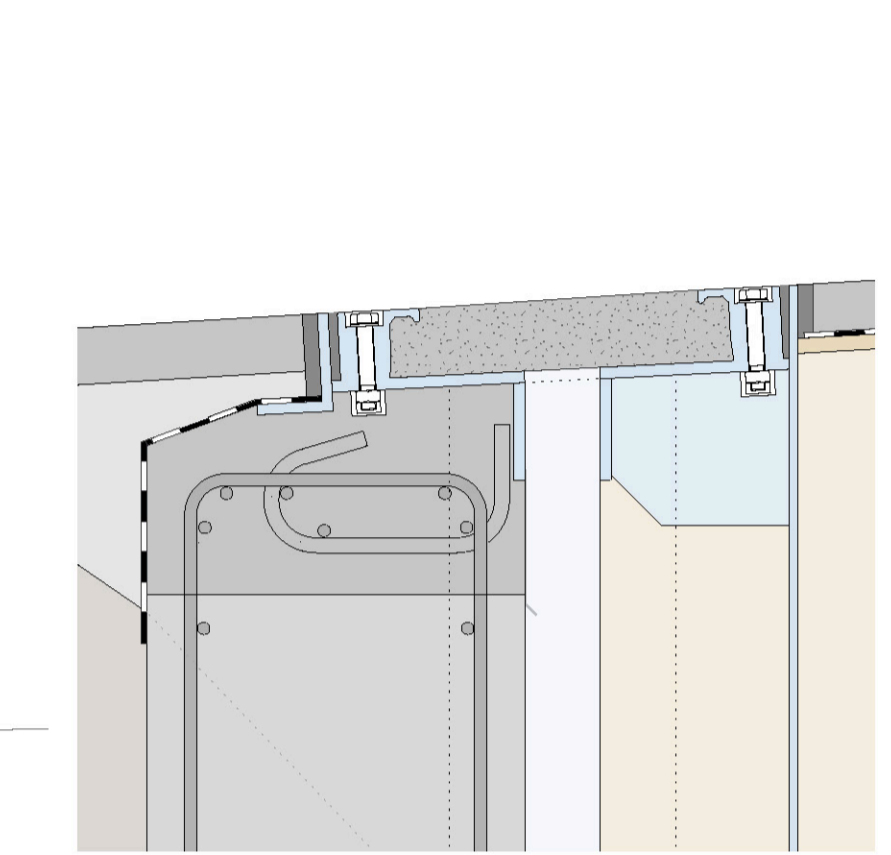

Detail Brückenentwässerung 1:50

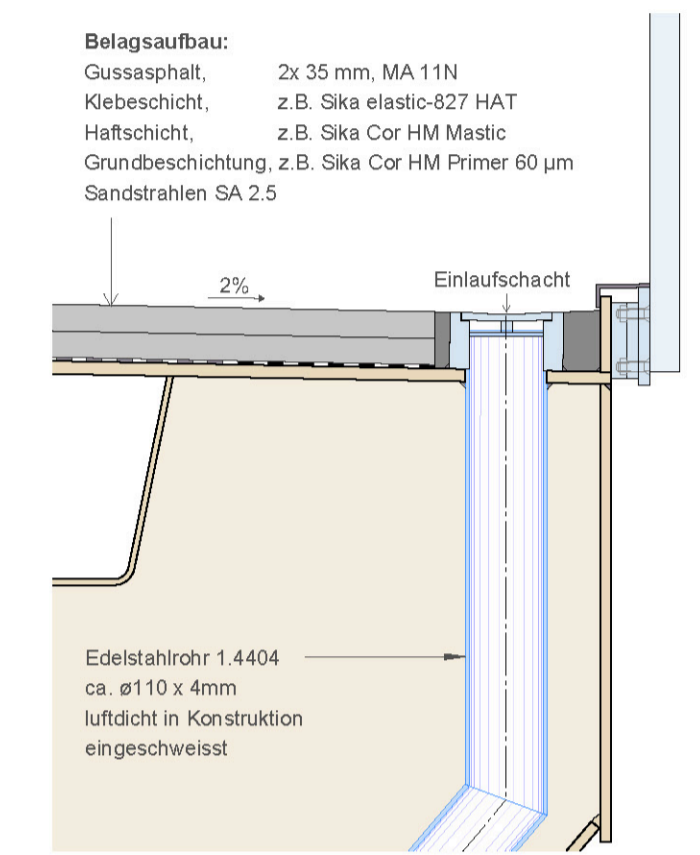

Phase 1a 1:250

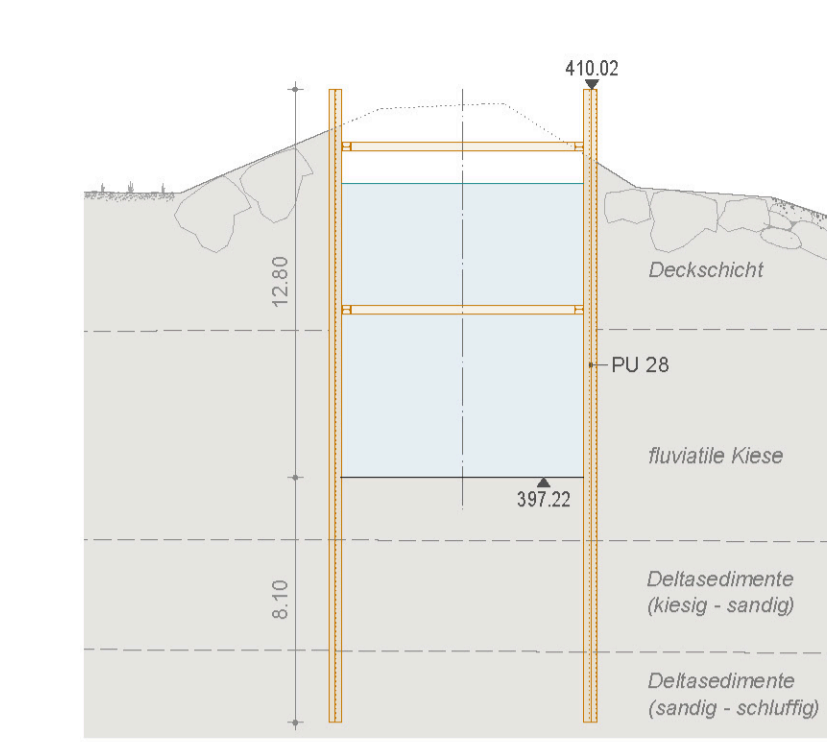

Widerlager Seite Diepdoldau / Stütze 4

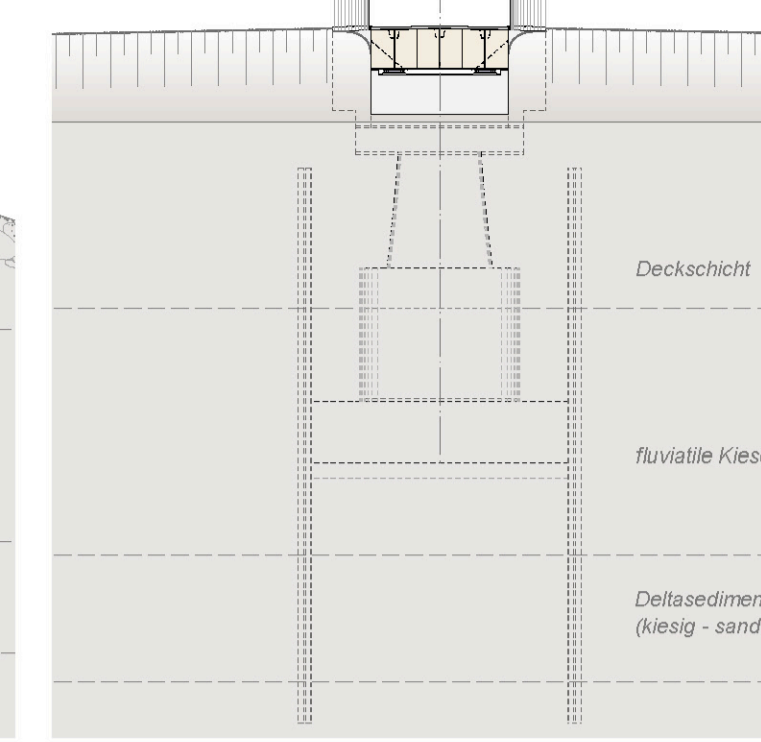

Phase 1b

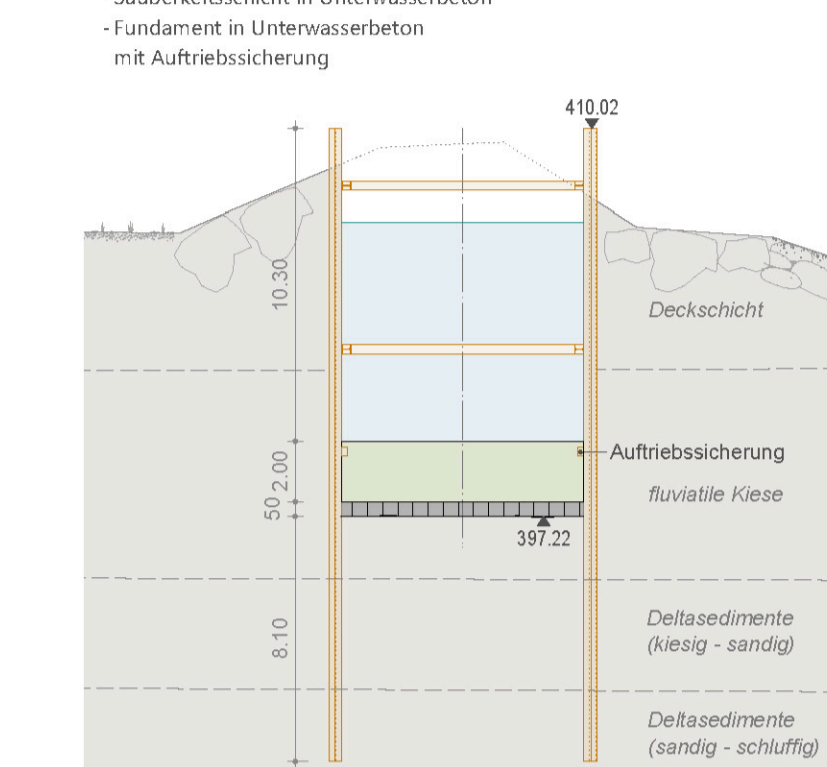

Phase 5a

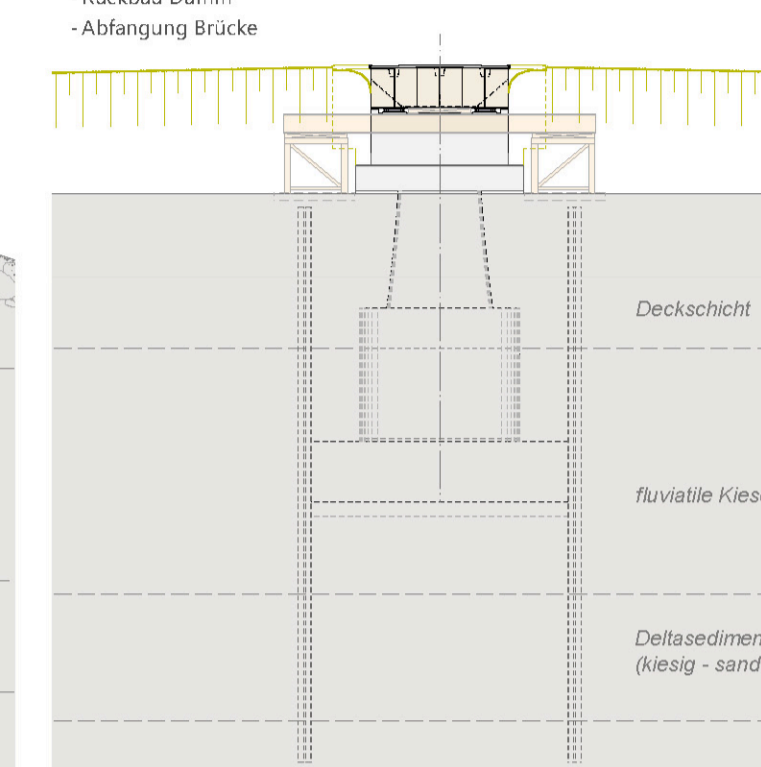

Phase 1c

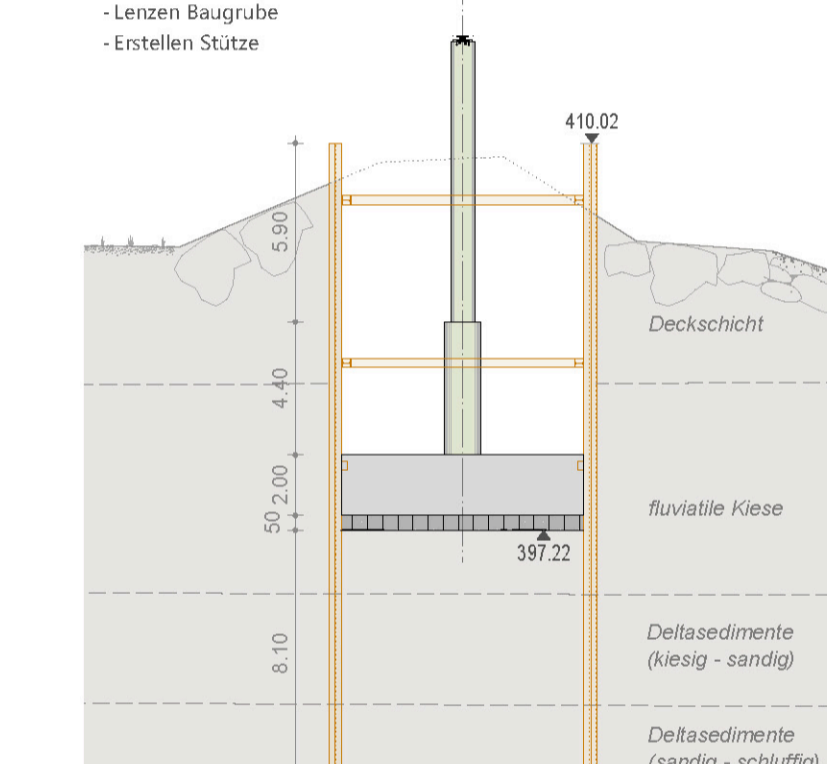

Phase 5b

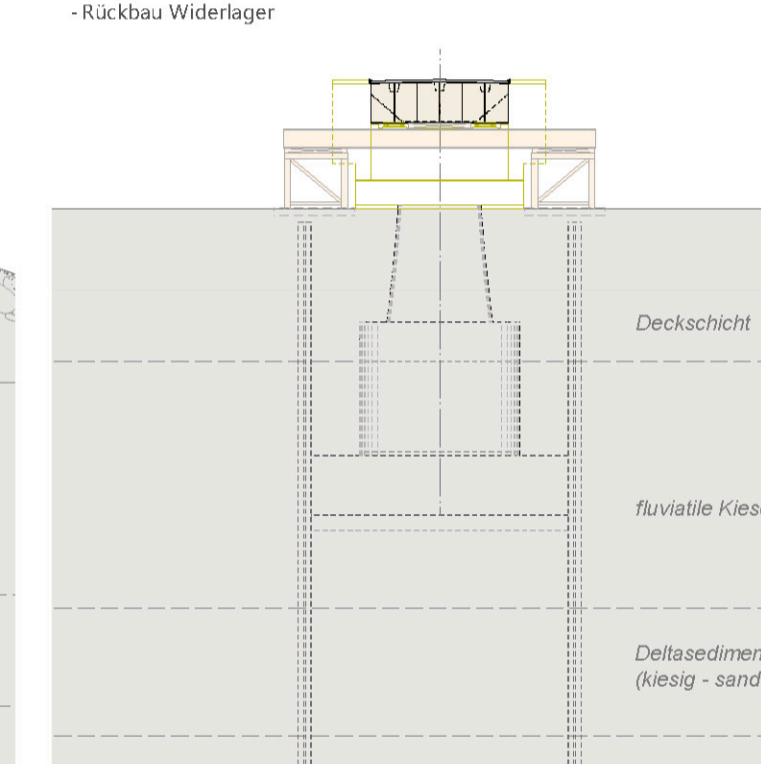

Phase 1d

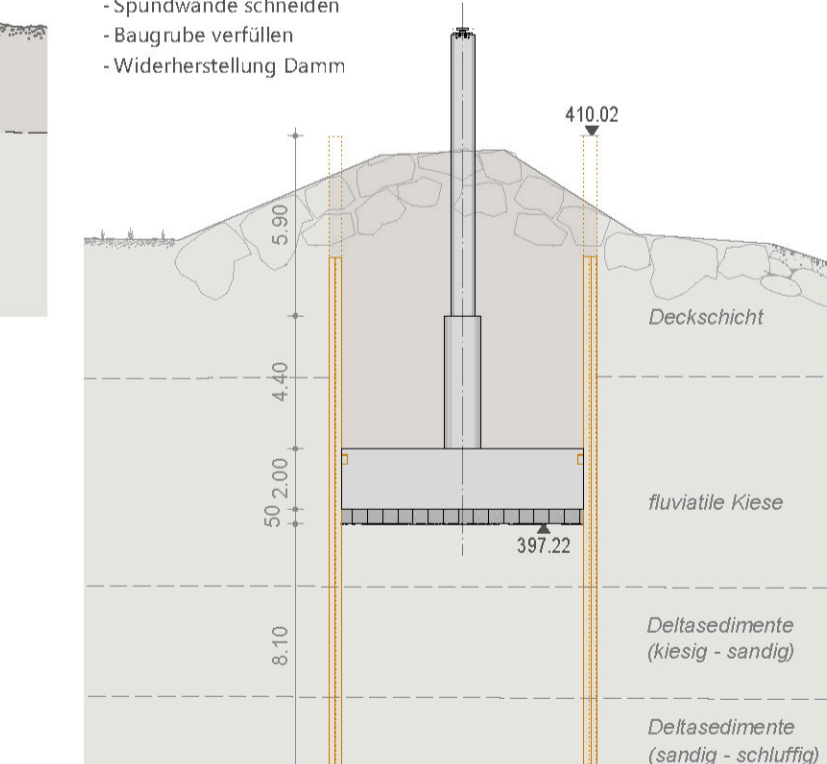

Phase 5c

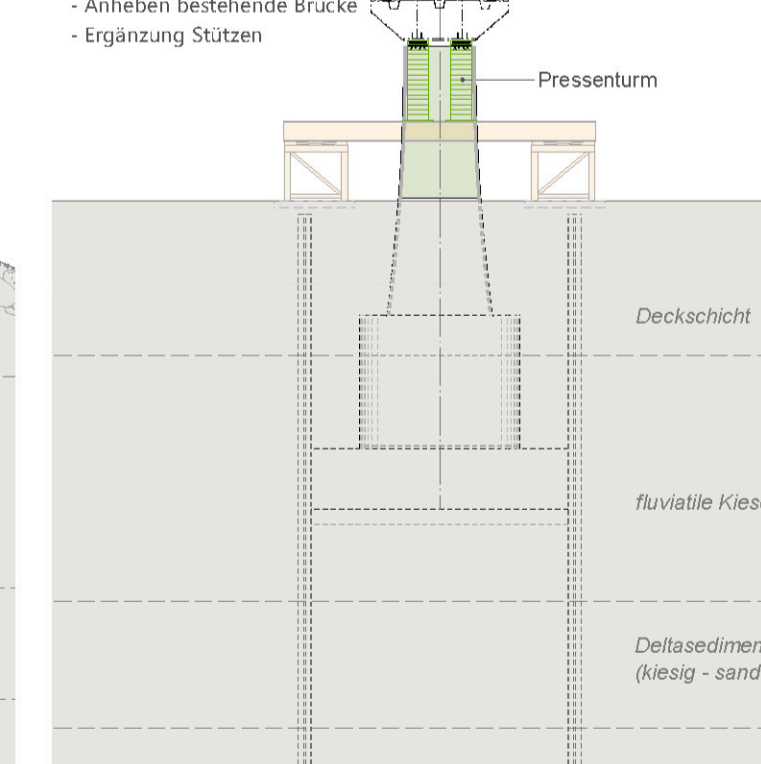

RHESI

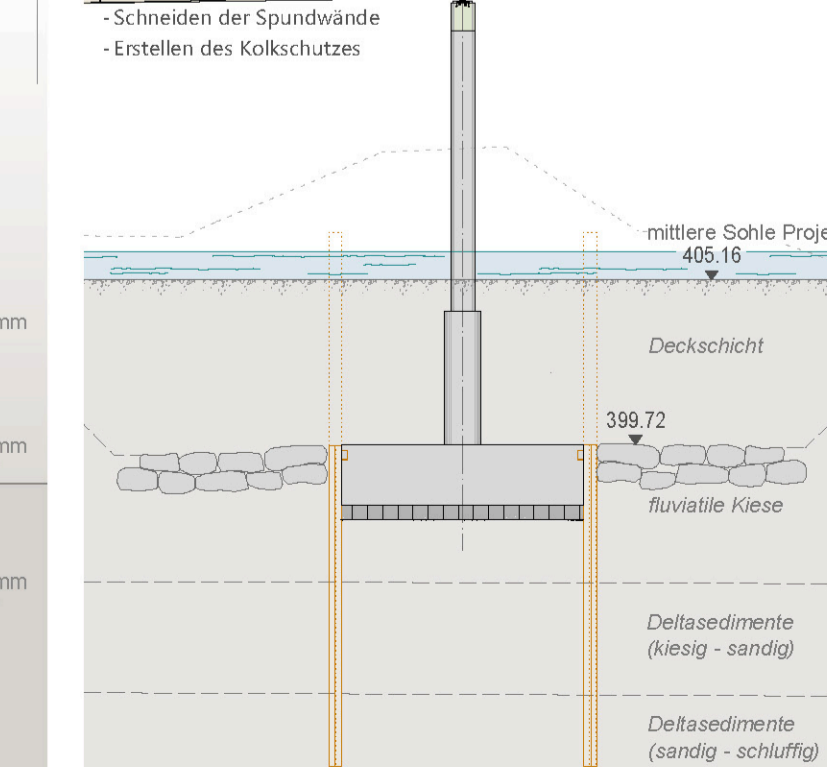

Phase 5d

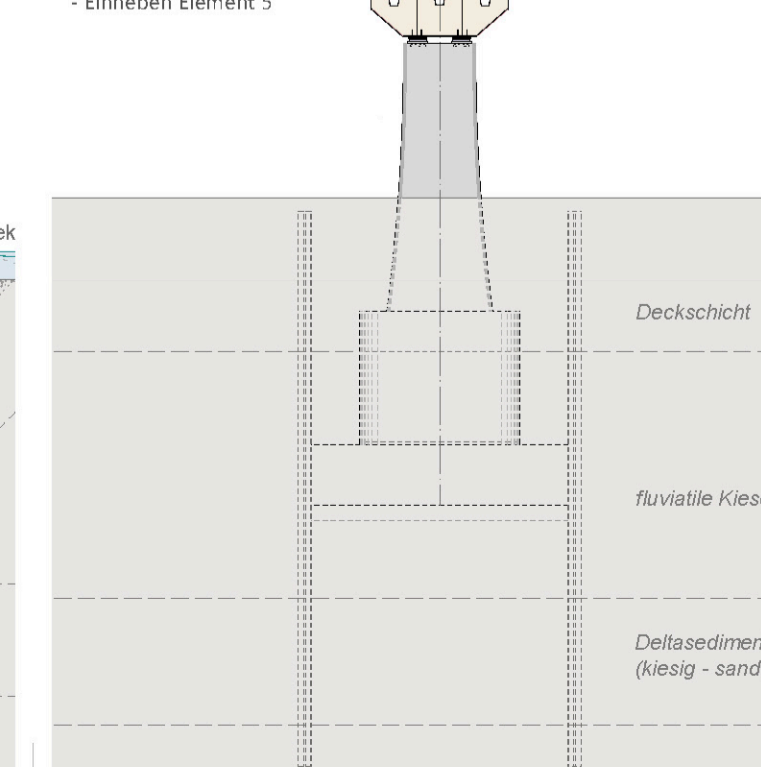

Situation 1:500

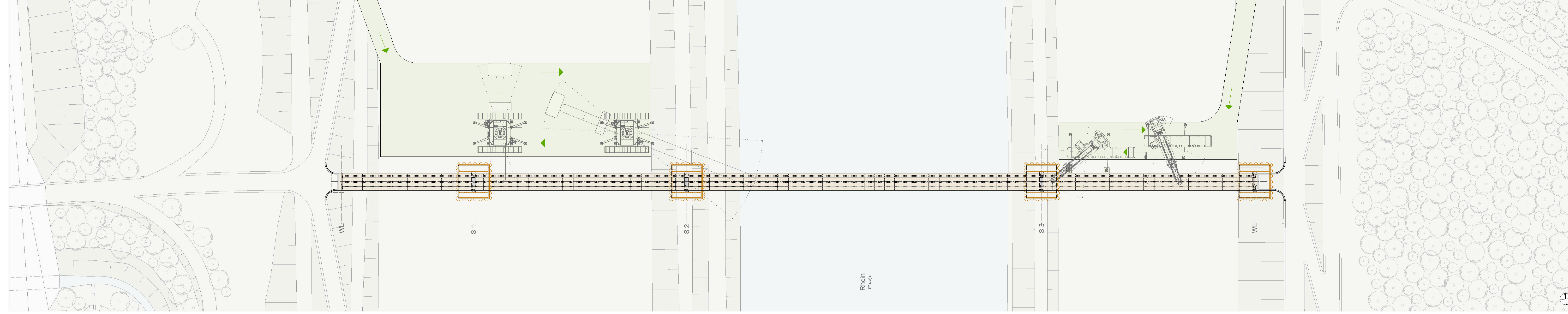

Bauphase 1 + 2 1:500

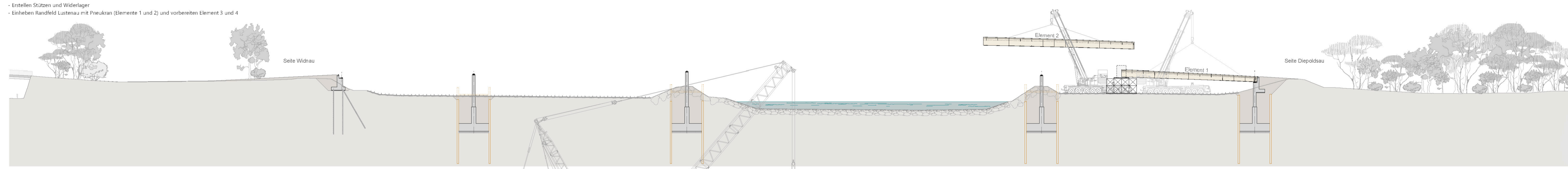

Bauphase 3

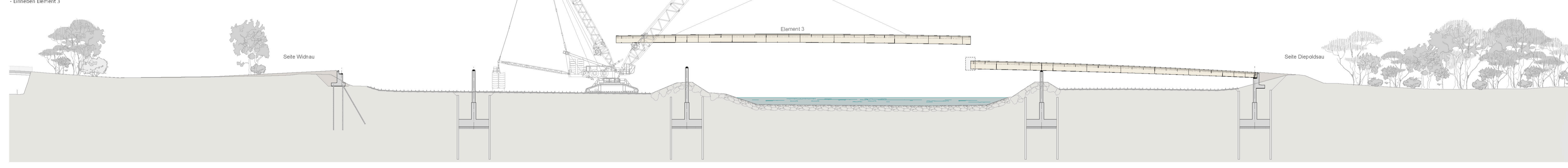

Bauphase 4

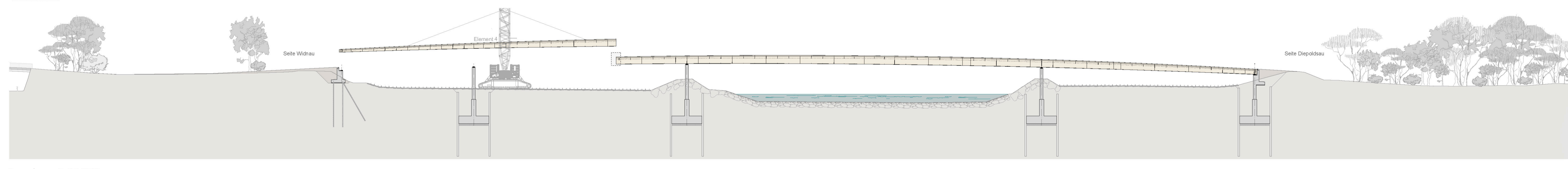

Bauphase 5 (RHESI)

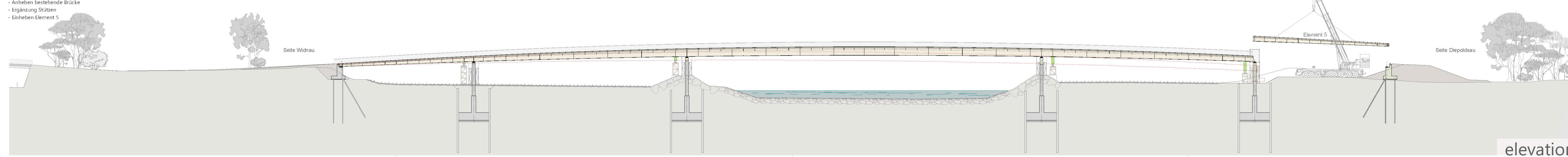

Schnitt C - C Fundament Stütze 1:50

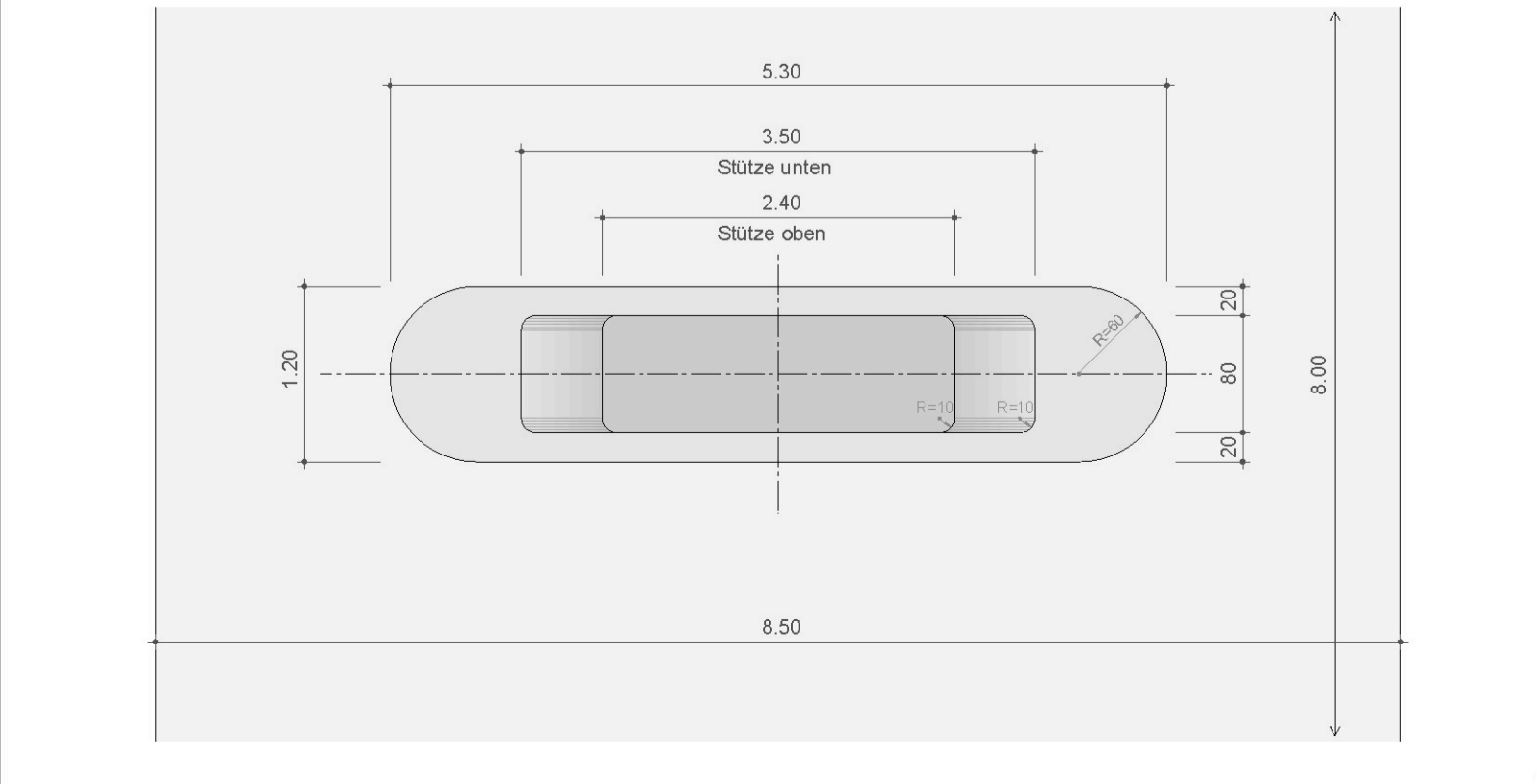

395.00 m ü. M.

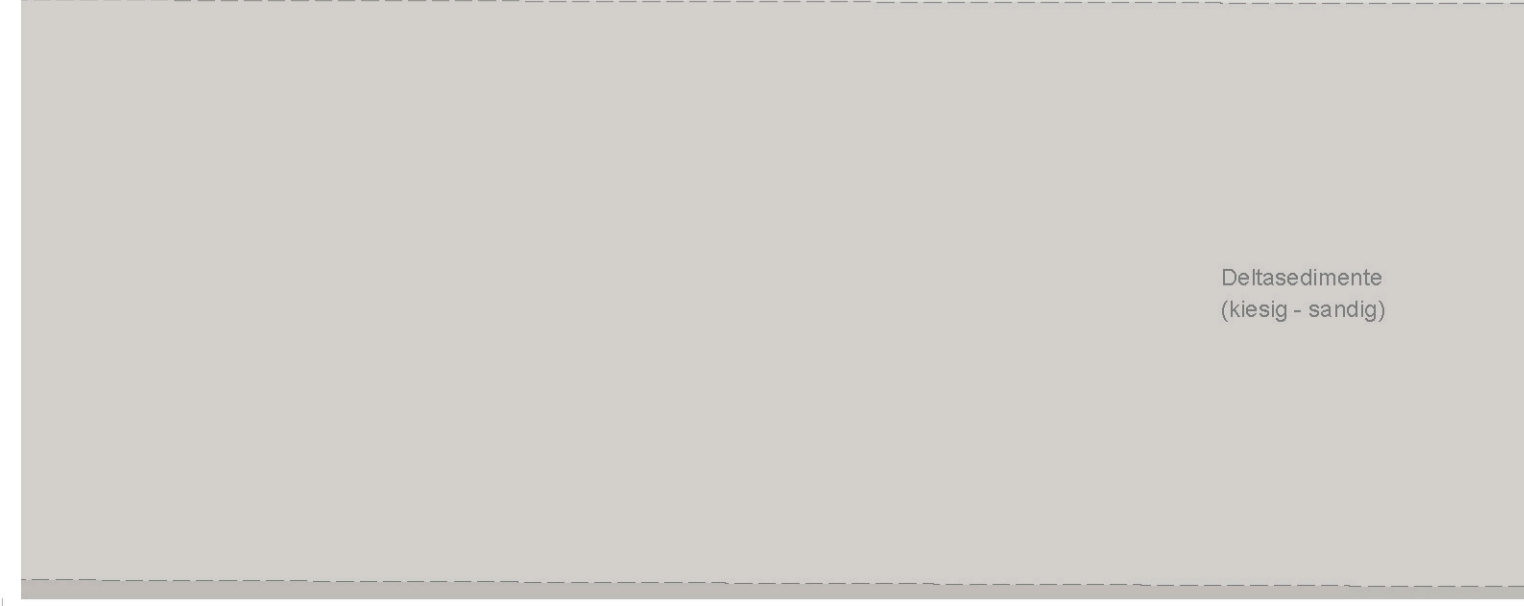

Schnitt Widerlager Seite Widnau 1:50

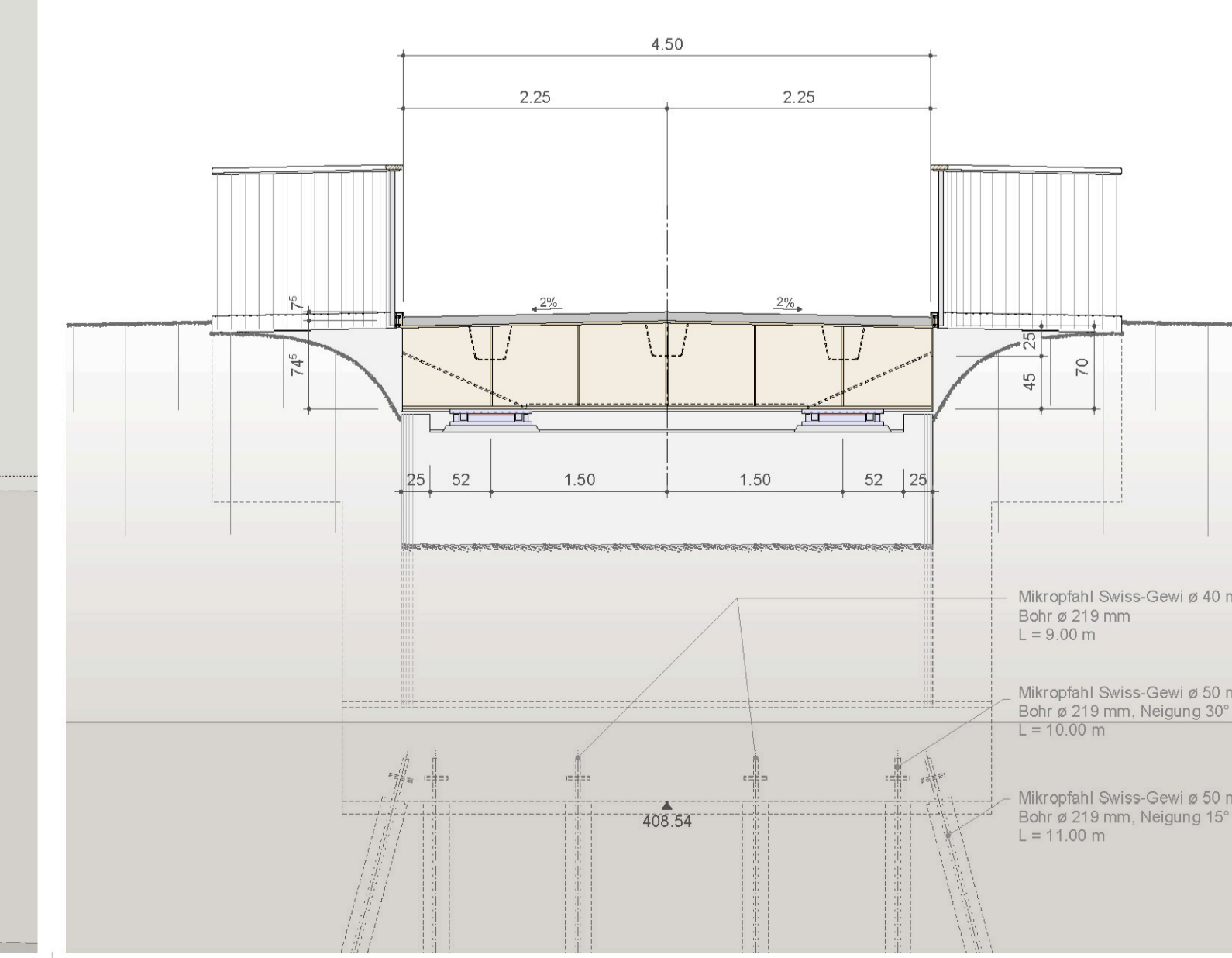

Ansicht Widerlager Seite Widnau 1:50

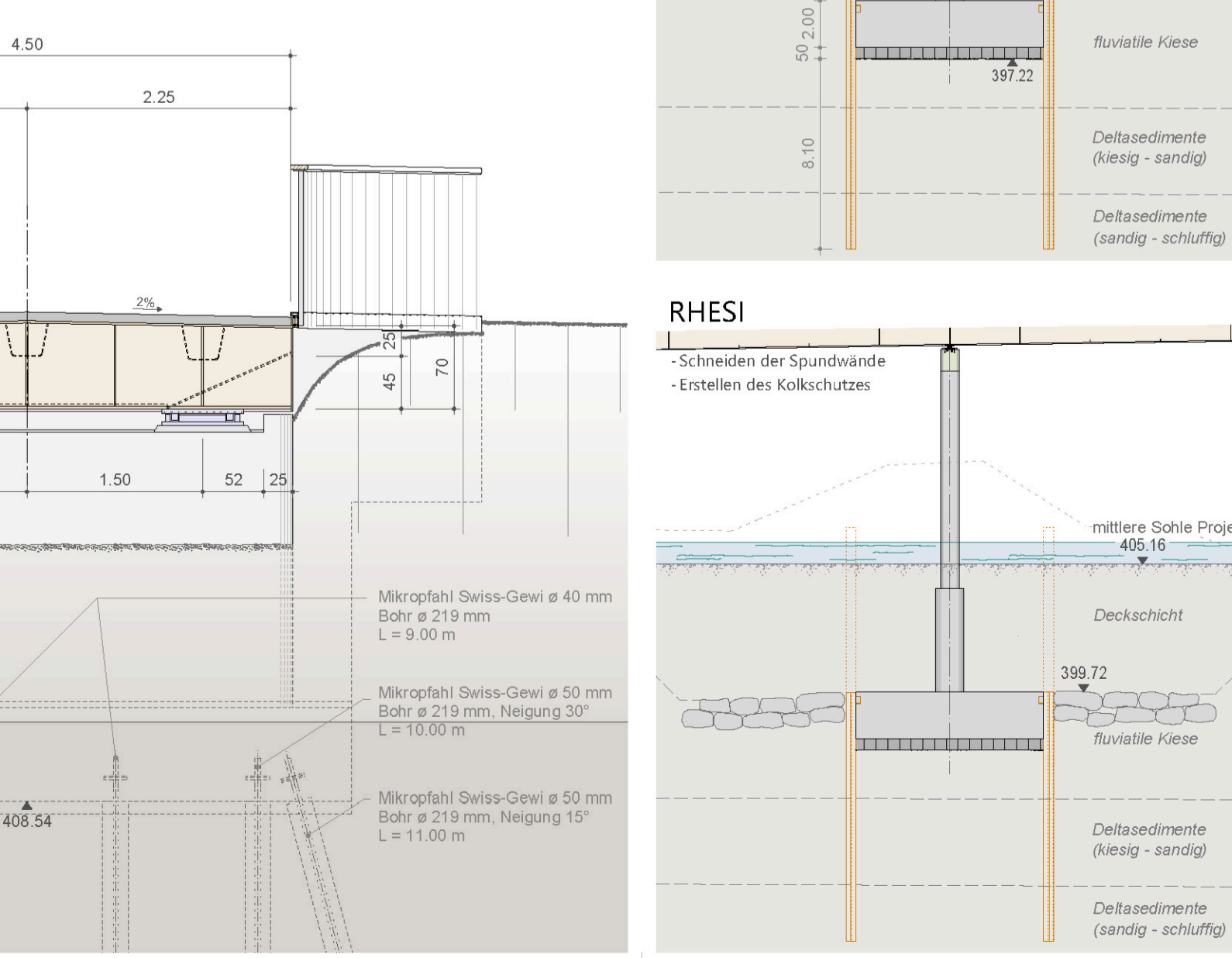






Zeichnung mit Wegverbindungen

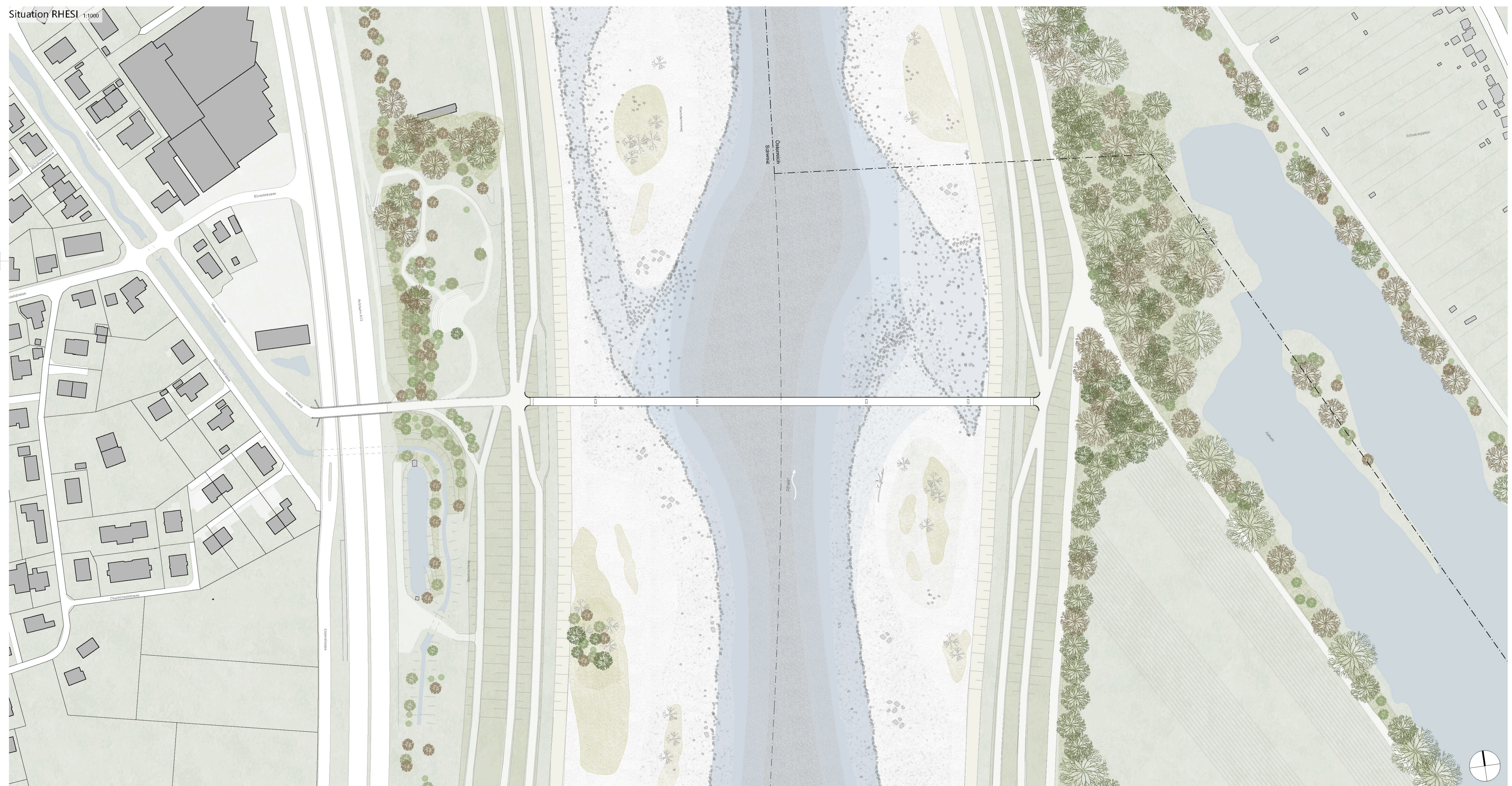

Zeichnung mit Blick Richtung Widnau

